

KC Series

MAGNETIC SEALLESS PUMPS

KC5.5, 6, 6H, 7, 8 & 10 Sealless* Centrifugal Pumps 1/3 to 1-1/2 HP (.19 to .55 kW)

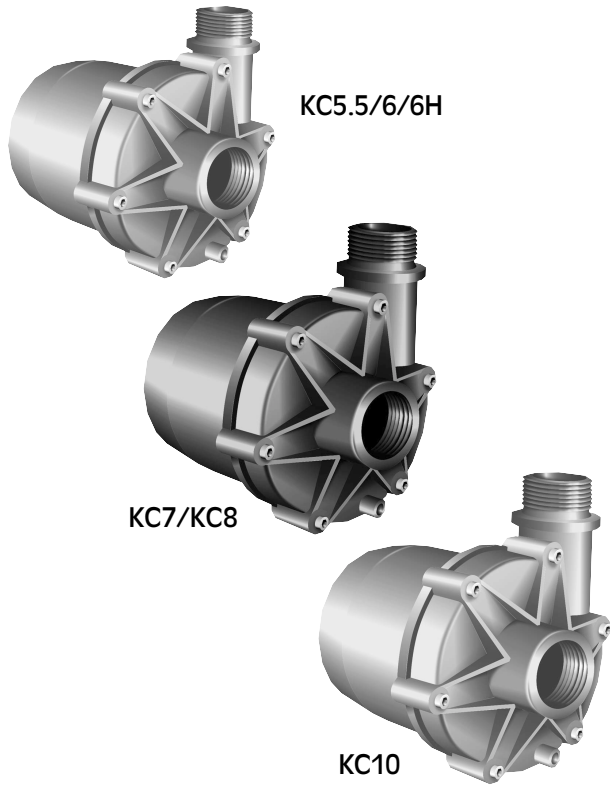

Features

- * Run-Dry
 - PVDF
 - NEMA 56C IEC 63/B14, 71/B14, 80/B14, 90/B14
 - TEFC Exp 575V
 - OEM
 - NPT BSP
 - 1/4" NPT
- * 24 Run-Dry가 가

Typical Applications

- Chemical processing
- Plating
- Printed circuit board manufacturing
- Semi-conductor
- Wet scrubber
- Photo processing
- Pulp and paper
- Pharmaceuticals
- Heat exchanger
- Water and waste water

Performance

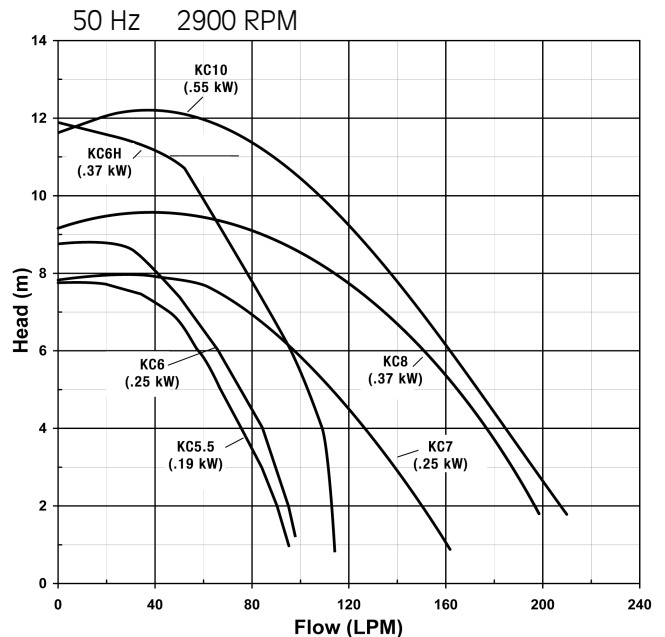
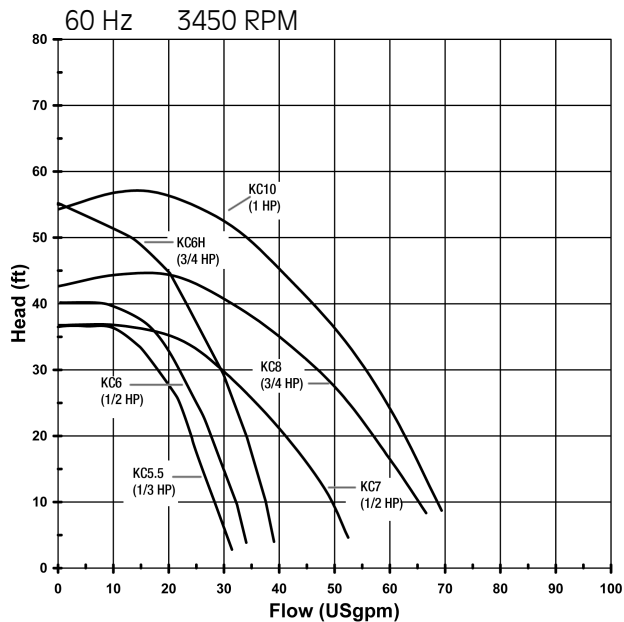

Specifications

MODEL NUMBER	SUCTION (FNPT/BSP)	IMPELLER SIZE		MAX. FLOW		MAX. HEAD		SPECIFIC GRAVITY* @ 30 CPS	MOTOR†		MAX. WORKING PRESSURE	WEIGHT**		MAX. TEMP. PP		MAX. TEMP. PVDF	
	DISCHARGE (MNPT/BSP)			3450 rpm	2900 rpm	3450 rpm	2900 rpm		HP	kW				°F	°C	°F	°C
		inch	cm	GPM	LPM	ft	m		psi	lbs	kg	°F	°C	°F	°C		
KC 5.5	1	3.0	7.6	31	95	36.7	7.8	1.4	1/3	.19	60	26	12	180	82	220	104
	3/4																
KC 6	1	3.19	8.1	33	99	39.8	8.6	1.4	1/2	.25	60	26	12	180	82	220	104
	3/4																
KC6H	1	3.88	9.9	38	115	55	11.8	1.4	3/4	.37	60	26	12	180	82	220	104
	3/4																
KC7	1 1/2	3.19	8.1	52	159	37	7.9	1.4	1/2	.25	60	26	12	180	82	220	104
	1																
KC 8	1 1/2	3.5	8.9	67	200	43	9.2	1.4	3/4	.37	60	32	15	180	82	220	104
	1																
KC 10	1 1/2	3.88	9.9	69	210	54	11.6	1.4	1	.55	60	40	18	180	82	220	104
	1																

*Obtainable without trimming impeller. Magnet upgrades available to handle higher specific gravities up to 1.8. Contact FTI.

**Varies with motor.

†HP recommendation is based on full flow and 1.0 specific gravity.

Note: Actual performance may vary. Pump models and performance vary with conditions.

Dimensions

MODEL NUMBER	MOTOR FRAME	A		B		C		D		E		F		G		H		J*	
		inch	cm	inch	cm	inch	cm	inch	cm	inch	cm	inch	cm	inch	cm	inch	cm	inch	cm
KC 5.5/6/6H NPT	56C	3-1/2		2-3/4		3		4-7/8		1-13/16		2-1/16		6		3-1/2		9	
KC 5.5/6/6H BSP†	71 B3/B14		7.1		4.5		9		11.2		4.6		5.2		15.3		8.9		21
KC7/8/10 NPT	56C	3-1/2		2-3/4		3		4-7/8		1-7/8		2-3/4		6-3/4		3-7/8		9	
KC7/8/10 BSP	80 B3/B14		8		5.0		10		12.5		4.8		7		17.1		9.8		25
KC7/8/10 BSP	90 B3/B14		9		5.6		10		14		4.8		7		17.1		9.8		27

*Varies with motor manufacturer.

†Available in 63 frame.

Models KC5.5, 6, 6H, 7, 8, 10

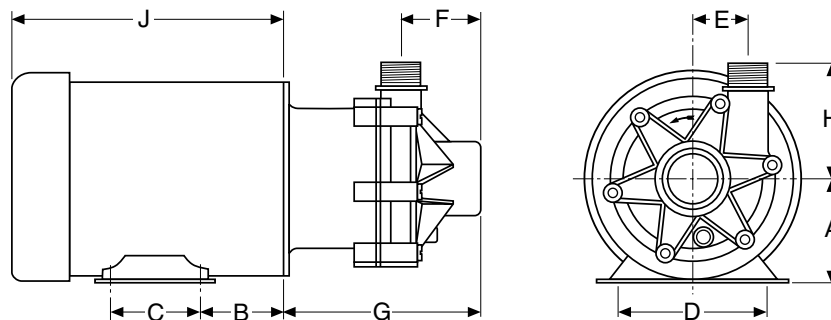

Drawings are for reference only.



FINISH THOMPSON INC.

921 Greengarden Road • Erie, PA 16501-1591 U.S.A.

Ph 814-455-4478 • Fax 814-455-8518

Email fti@finishthompson.com • www.finishthompson.com

Toll Free USA & Canada 1-800-934-9384

Literature I.D. No. - FT95-584K, 9/03

