



Model FT05 - 메탈

AIR OPERATED DOUBLE DIAPHRAGM PUMPS

펌프 사양

- 흡입/토출 구경 : 1/2" x 1/2"
- 표준포팅 위치 : 끝
- 배관 연결 드레드 타입 : NPT, BSP
- 공기흡입 & 배기 사이즈 : 1/4"FNPT x 1/2"FNPT
- * NPT 나 BSP 드레드의 중앙포팅위치는 '수평' 아니면 '수직' 옵션임

펌프 능력/용량

- 최대유량 : 77 lpm
- 최대공기공급압 : 8.3 Bar
- 한타당 용적 : 0.08 Liter
- 최소공기흡입압 : 0.7 Bar
- 입자 최대사이즈 : 4.7mm
- 소음레벨: 72.1 dB(A)
- 가동온도 : 탄성체에 의해 결정



FT05 Performance

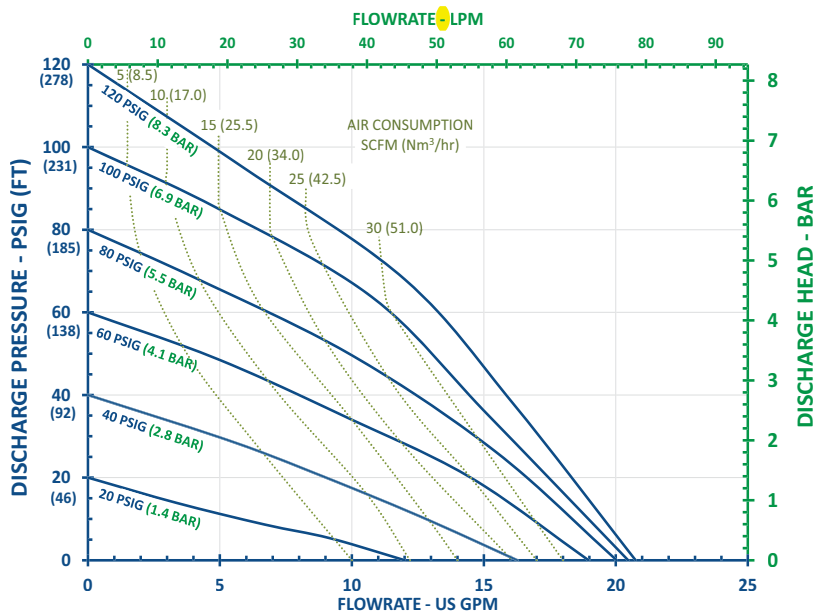

Note: Full stroke diaphragm allows performance to be equal for all elastomers.

Typical Applications

- Acids & Bases
- Plating Solutions
- Wastewater
- Paints, Inks, Solvents
- Ceramic Slip and Glaze
- Lubricants and Oils

Typical Industries

- Mining
- Paints and Coatings
- Ceramics
- Pulp and Paper
- Electroplating & Anodizing
- Wastewater
- Marine
- Chemical Manufacturing & Distribution
- OEM's

펌프 구조

- 접습면 재질 : 알루미늄, 스텐 SS316,
- 다이어프램 재질 : 네오프렌, 산토프렌, FKM, EPDM, PTFE, Buna, Hytrel, Polyurethane
- 에어발브 : GFRP, 알루미늄
- 볼 재질 : 네오프렌, Buna, EPDM, FKM, 산토프렌, PTFE
- 시트 재질 : 알루미늄, 스텐 SS316, PTFE
- 오링 재질 : 네오프렌, Buna, EPDM, FKM, PTFE, FEP/FKM

*산토프렌은 엑손모빌사의, 하이트렐은 듀폰사의 등록상표임.

펌프 사이즈

- 최대 높이 : 250 mm
- 최대 너비 : 246 mm
- 최대 깊이 : 204 mm

펌프 무게

- 알루미늄 : 5.3 Kgs
- 스텐 : 7.0 Kgs

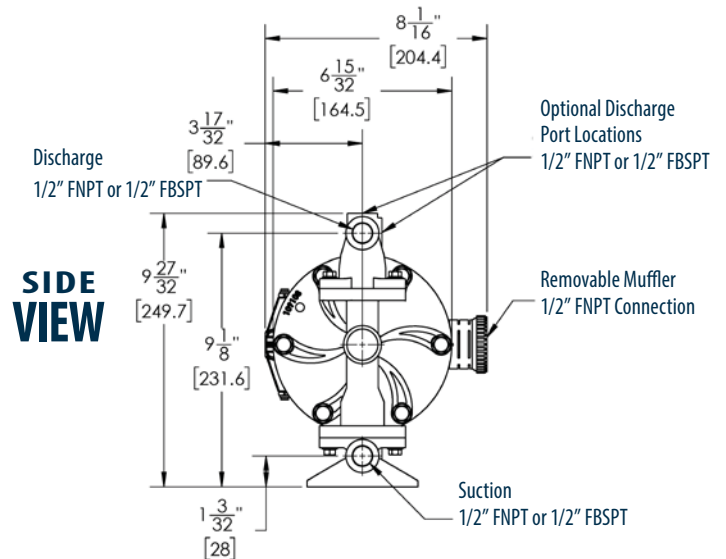
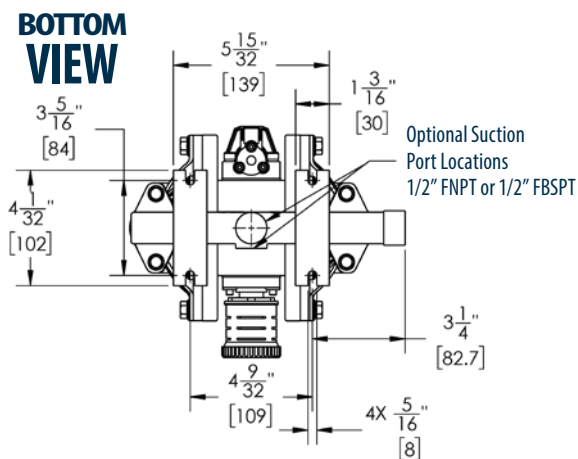
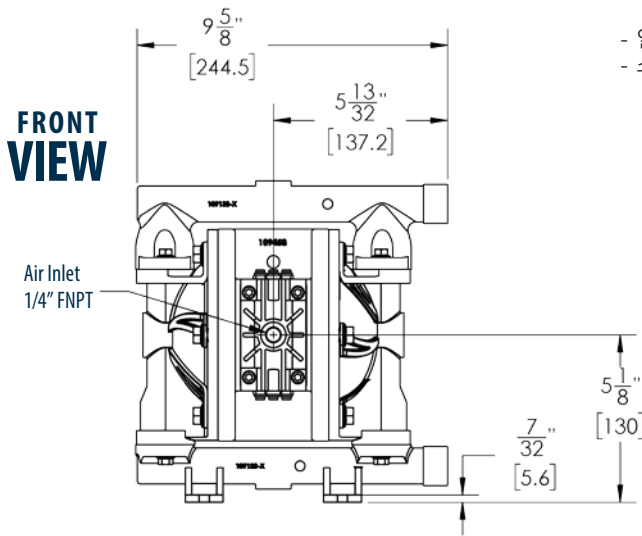

FTI AIR

921 GREENGARDEN ROAD ERIE, PA 16501
Tel: (800) 934-9384 • Fax: (814) 459-3460
www.FTIAIR.com

